

Owner's Guide

Silhouette[®] Window Shadings

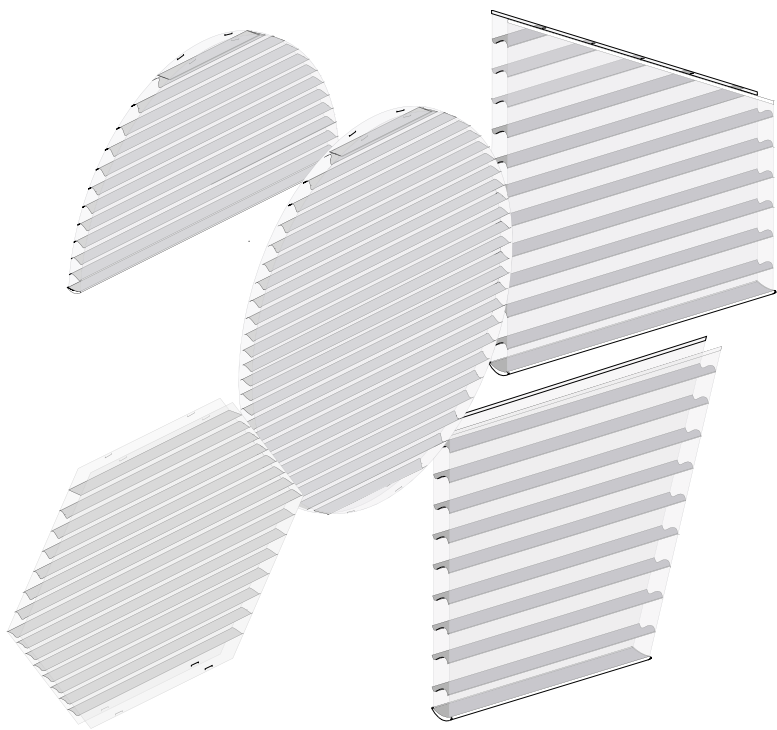

Specialty Shapes

HunterDouglas

CONTENTS

Introduction	2
Before You Begin	2
Specialty Shape Shadings.....	3
CHANNEL MOUNT SHADINGS	5
Exploded View.....	6
Getting Started.....	7
Tools And Fasteners Needed.....	7
Installation	8
Troubleshooting.....	14
STOP-STRIP MOUNT SHADINGS	15
Exploded View.....	16
Getting Started.....	17
Tools And Fasteners Needed.....	17
Installation	18
Troubleshooting.....	22
Care And Cleaning	23

INTRODUCTION

THANK YOU for purchasing a Hunter Douglas product. Your new shading has been custom built for you from the highest quality materials. Once in your window, it will provide you with a lifetime of beauty and trouble-free use.

BEFORE YOU BEGIN

Installation has been designed to be as simple as possible. Please review the instructions to acquaint yourself with all of the procedures.

If you need any assistance with operation or adjustments, call the Hunter Douglas Customer Information Center at:

1-888-501-8364

SPECIALTY SHAPE SHADINGS

Specialty shape Silhouette® shadings come in a variety of shapes and sizes for your needs. Refer to the appropriate section for your type of shading.

Channel Mount Shadings, page 5



Top Channel Mount/Bottom Rail

Arch, extended arch, quarter circle, imperfect arch, and imperfect quarter circle.

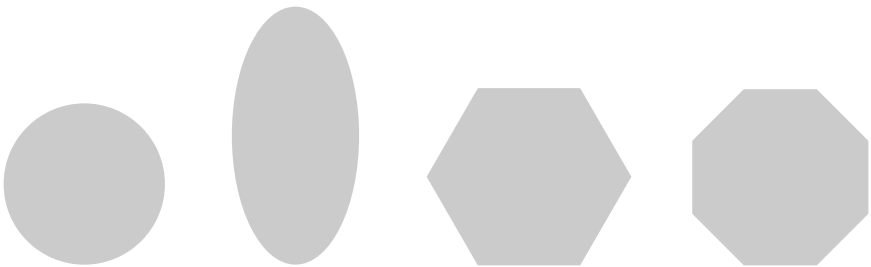

Top Channel Mount/Bottom Channel Mount

Circle, oval, hexagon, octagon.

Stop-Strip Mount Shadings, page 15



Stop Strip Mount/Bottom Rail

Angle and trapezoid.

CHANNEL MOUNT SHADINGS

**Arch, Extended Arch, Quarter Circle,
Circle, Oval, Hexagon, Octagon, Imperfect Arch,
Imperfect Quarter Circle**

EXPLODED VIEW

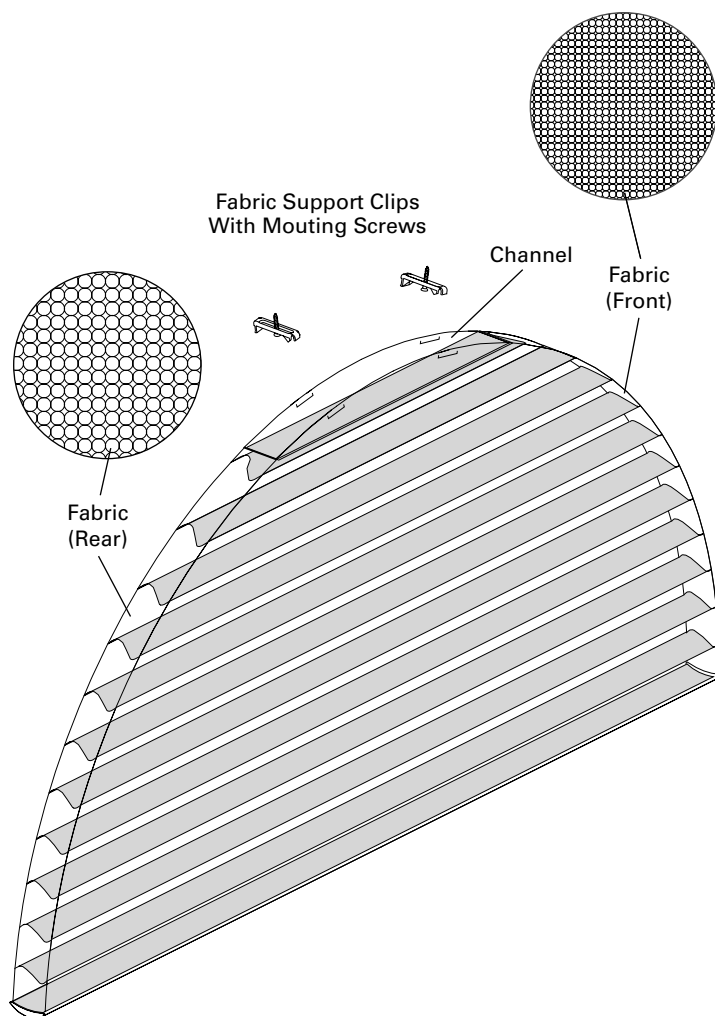

Arch shading illustrated.

GETTING STARTED



- Remove the materials from the package. Keep the packaging until the shading meets your satisfaction.
- Save these instructions for care and cleaning, shading removal, and reinstallation procedures.
- Check the exploded view to make sure you have the necessary parts.

TOOLS AND FASTENERS NEEDED

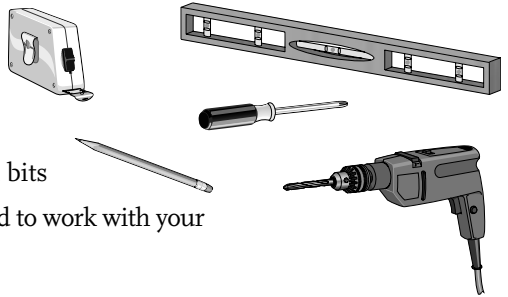
- Level
- Measuring tape
- Pencil
- Phillips screwdriver
- Power drill, 1/4" driver, and drill bits



You will also need fasteners designed to work with your specific mounting surface.

Mounting Surface	Fastener
Wood	No. 6 Flathead Screws (Provided) 
Drywall, Plaster	Wall Anchors, Expansion Bolts (Not Provided) 
Metal	Sheet Metal Screws (Not Provided) 

Materials provided with your shading:

Your order should include:

- Fabric support clips
- Flathead Phillips screws (one for each bracket)

Install The Top Channel

Arch, Extended Arch, Circle, Oval, Hexagon, Octagon Shadings

1. Clear a flat, clean workspace.
2. Place the shading with the front side of the fabric facing up. Handle the fabric carefully throughout the installation process. The fabric support clips are pre-attached to the shading.
3. Locate and mark the top center of the window casement. One method is to use a plumb line, as shown.
 - a. Measure the bottom sill and divide in two to locate center and mark the location.
 - b. Move the plumb line until the bob aligns with the center mark on the sill, then mark the location on the top sill.

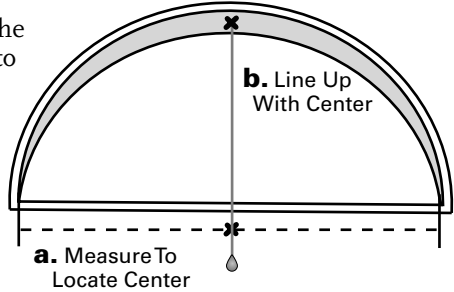

NOTE: Locating the exact center is very important for the shading to hang level and evenly in the window.

4. Center the space between the two fabric support clips attached to the fabric on the center mark on the casement.

5. Mark the location for the mounting screws.

- The minimum flush mounting depth is the vane size of the shading, 2" or 3".
- The minimum mounting depth for screw placement is $\frac{7}{8}$ ".

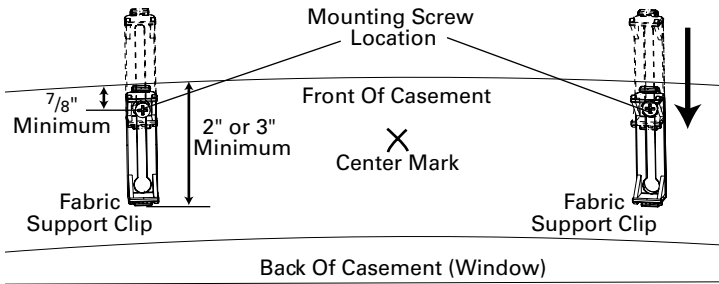
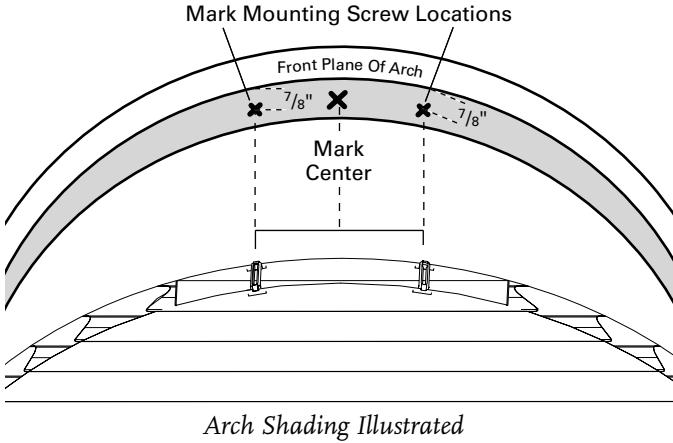

6. Install the screws where marked. Install the screws at an angle perpendicular to the mounting surface. Leave the screw head partially unseated, approximately $\frac{3}{8}$ ".

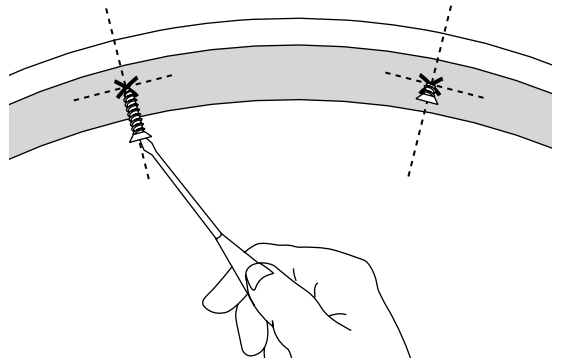

Quarter Circle Shadings

1. Clear a flat, clean workspace.
2. Handle the fabric carefully throughout the installation process. The fabric support clips should be attached to the shading.
3. Hold the shading up to the window (front side of the fabric facing forward) and position as desired.
4. Mark the location for the mounting screws at the fabric support clips.
 - The minimum flush mounting depth is the vane size of the shading, 2" or 3".
 - The minimum mounting depth for screw placement is $\frac{7}{8}$ ".

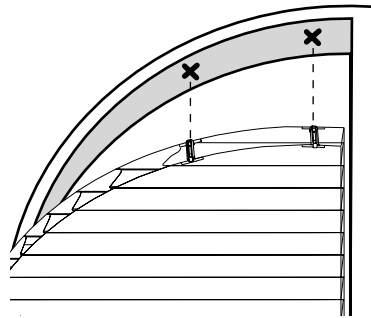

Mount The Top Channel

Arch, Extended Arch, Circle, Oval, Quarter Circle, Hexagon, Octagon Shadings

1. Hold the shading up to the window casement with the keyhole on the fabric support clips to the back.
2. Slide the keyhole of each fabric support clip over the adjacent screw head.
3. Slide the shading back until secure.

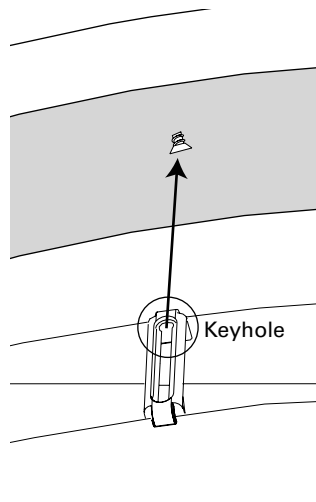

Install The Bottom Channel

Circle, Oval, Octagon, Hexagon Shadings

1. With the top channel mounted, center the bottom channel over the bottom sill.
2. Using the fabric support clips as a guide, mark the location for the brackets.

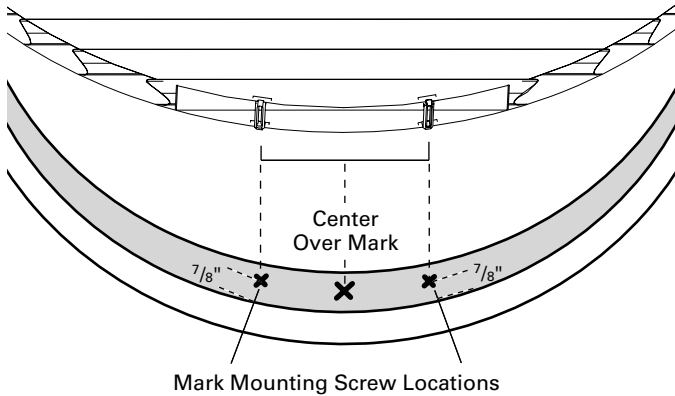

Oval shading illustrated.

3. Install the screws where marked at the same depth (minimum is $7/8''$) as the screws mounting the top channel. Install the screws at an angle perpendicular to the inside of the mounting surface. Leave the screw head partially unseated, approximately $3/8''$.

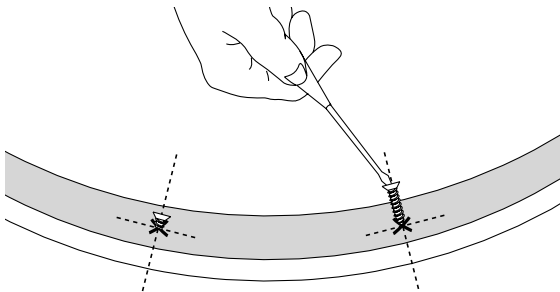

Mount The Bottom Channel

Circle, Oval, Hexagon, Octagon Shadings

1. Slide the keyhole of each fabric support clip over the adjacent screw head.
2. Slide the bottom channel back until secure.

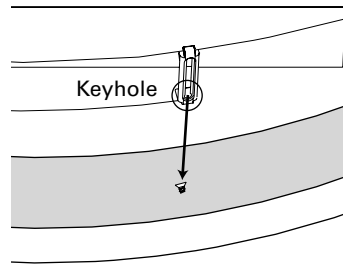

Adjust The Shading

Arch, Extended Arch, Circle, Oval, Hexagon, Octagon Shadings

The shading should be level and hang straight for the best appearance.

To level or straighten:

- Slide the shading slightly right or left at the clips on the top channel and the bottom channel (where applicable). Be careful not to detach the shading from the clips.

Or

- Loosen a top mounting screw to drop the corresponding rail side. Loosen a bottom mounting screw (where applicable) to straighten.

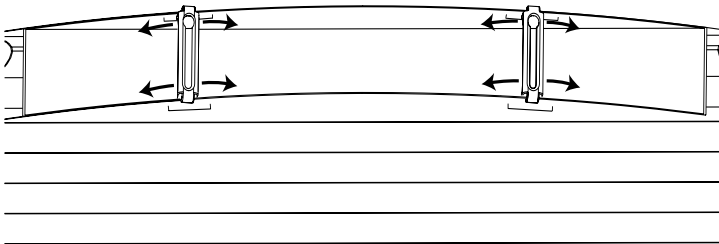

TIP: To reduce the tension on the fabric and clips, loosen the mounting screws. For arch shadings, allow the bottom rail to rest on the window sill. To tension the fabric, tighten the mounting screws.

Quarter Circle Shadings

■ Lower the mounting screws until the bottom rail rests on the window sill.

Or

■ Add a spacer between the bottom rail and the window sill to support the bottom rail. If there is no window sill, add the spacer to the straight side.

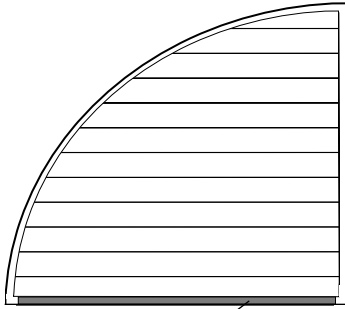

Add Spacer To Sill

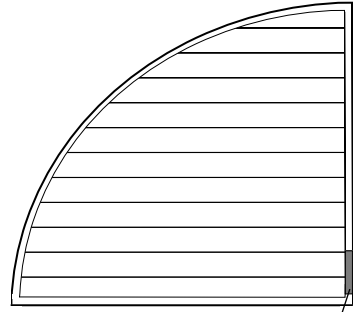

Add Spacer To Side
(If No Sill)

Remove The Shading

All Channel-Mount Shapes

1. Slide the shading forward at the fabric support clips.
2. Release the mounting screw from the keyhole in the fabric support clip and remove the shading.

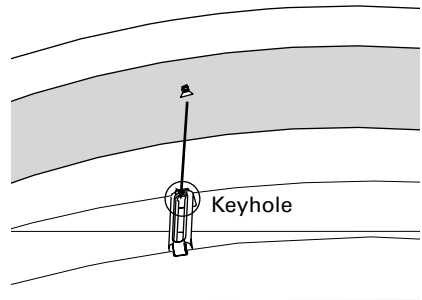

TROUBLESHOOTING

Problem	Solution
The shading or bottom rail does not appear straight.	<ul style="list-style-type: none">■ Verify that the screw placement is accurate. See <i>Install The Top Channel</i>, page 8, and <i>Install The Bottom Channel</i>, page 11.■ Slide the shading slightly at the clips to level the bottom rail. See <i>Adjust The Shading</i>, page 12.■ The window casement may be uneven. Adjust the mounting screw height to compensate. See <i>Install The Top Channel</i>, page 8.
The shading is not centered in the window.	<ul style="list-style-type: none">■ Verify the center of the window and verify that the mounting screws were accurately mounted. See <i>Install The Top Channel</i>, page 8, and <i>Install The Bottom Channel</i>, page 11.

STOP-STRIP MOUNT SHADINGS

Angle And Trapezoid

EXPLODED VIEW

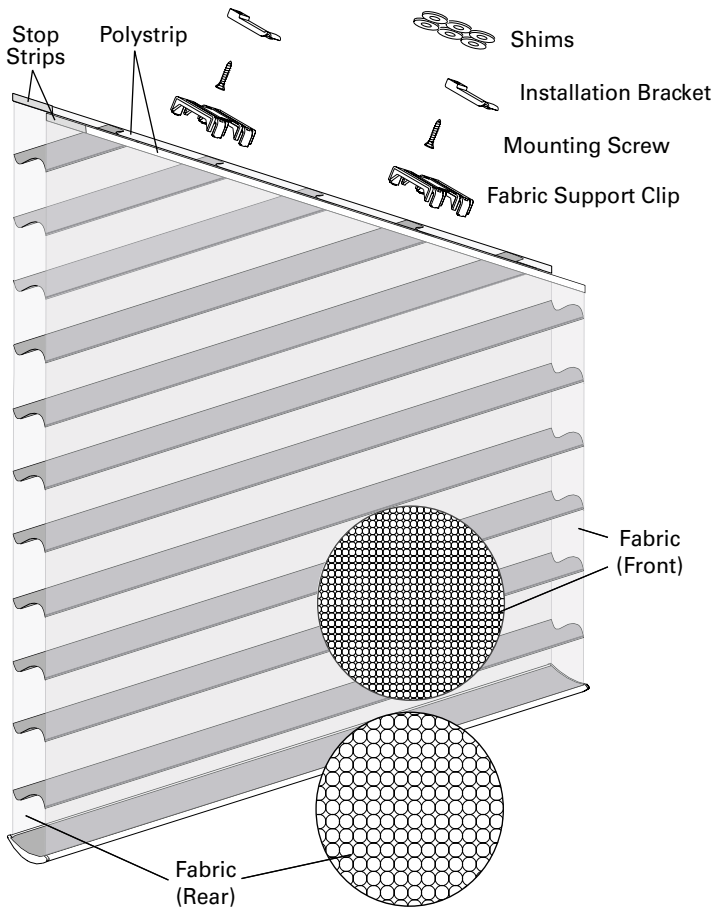

Angle shading illustrated.

GETTING STARTED



- Remove the materials from the package. Keep the packaging until the shading meets your satisfaction.
- Save these instructions for care and cleaning, shading removal, and reinstallation procedures.
- Check the exploded view to make sure you have the necessary parts.

TOOLS AND FASTENERS NEEDED

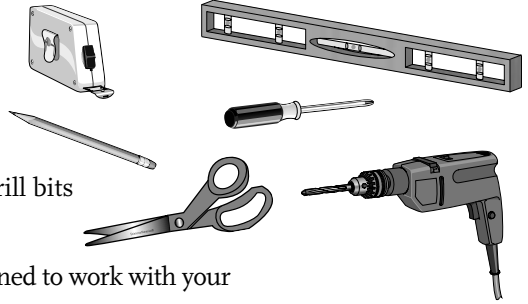
- Level
- Measuring tape
- Pencil
- Phillips screwdriver
- Power drill, 1/4" driver, and drill bits
- Scissors



You will also need fasteners designed to work with your specific mounting surface.

Mounting Surface	Fastener
Wood	No. 6 Flathead Screws (Provided) 
Drywall, Plaster	Wall Anchors, Expansion Bolts (Not Provided) 
Metal	Sheet Metal Screws (Not Provided) 

Materials provided with your shading:

Your order should include:

- Brackets (one for each fabric support clip)
- Drill template
- Fabric support clips
- Flathead Phillips screws (one for each bracket)
- Adhesive-backed stop strip (two)
- Shims (plastic washers)

INSTALLATION

Attach Fabric Support Clips

1. Clear a clean, flat workspace.
2. Place the shading with the front side of the fabric facing up. Handle the fabric carefully throughout the installation process.
3. Unroll the supplied Drill Template and lightly tack it to the work surface alongside the top edge of the shading.
4. Carefully lift the top edges of the front and back panels. Snap the fabric support clips onto the plastic polystrips attached to the panels.
5. Align the fabric support clips with the drill marks on the template. The clip positions can be adjusted by sliding them along the polystrip as needed when you install the shading.

NOTE: The drill template locates the fabric support clips between 6" and 10" apart, depending upon vane spacing. Do not place clips over the end of a fabric vane.

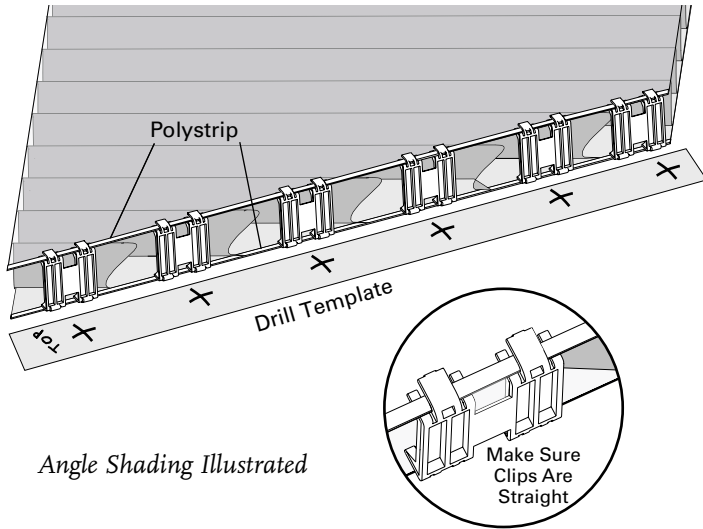

Install The Brackets

Install the brackets to the window casement.

1. The minimum mounting depth for a fully recessed shading is the vane size of the shading, 2" or 3".
2. Affix the supplied drill template to the window casement.
 - Place the end marked TOP approximately $\frac{1}{4}$ " away from the upper corner of the casement.

- Align the drill marks on the template in a straight line even with where you want to place the back edge of the shading. (The mounting screws for the fabric support clips align with the rear fabric edge on the shading.)
- Center the Drill Template in the casement. The space between the end of the Drill Template tape and the side wall of the casement should be even on both sides.

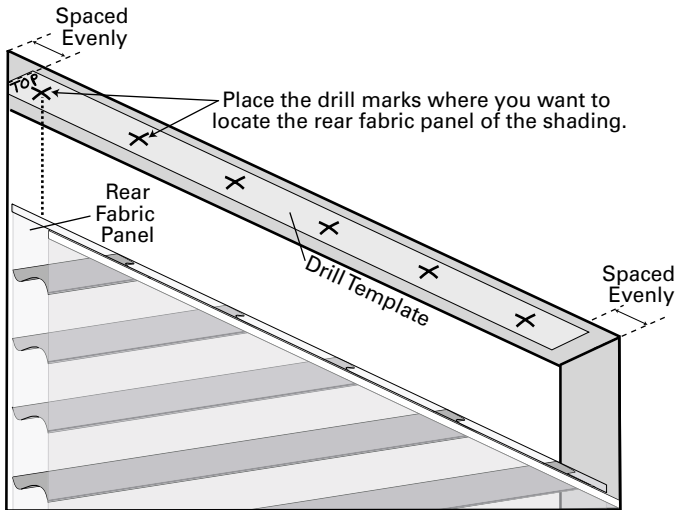

3. Drill pilot holes at the locations marked on the tape.
4. Remove the tape and attach one bracket per hole.
5. If necessary, use shims to accommodate for an uneven window casement.

TIP: If using more than one shim, fold the shims together (they come connected), rather than separating and stacking them.

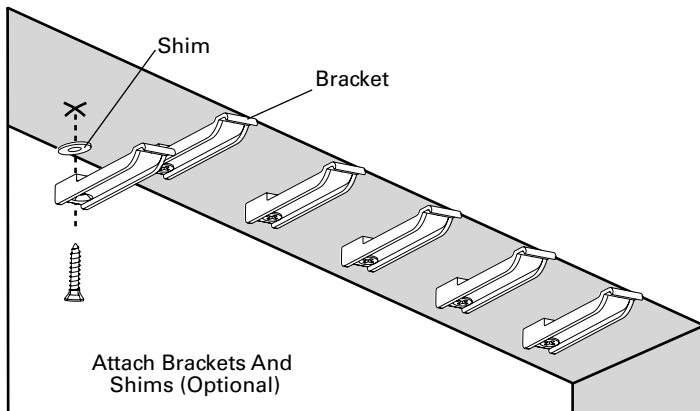

Mount The Shading

1. Hold the shading up to the brackets with the front side of the shading facing forward.
2. Starting at the top, slide each fabric support clip, one at a time, onto a bracket until the shading is secure. If necessary, slide each clip along the polystrip to align it with the bracket.
3. Stop strips have been pre-installed at the one end of each polystrip to prevent it from sliding through the fabric support clips.

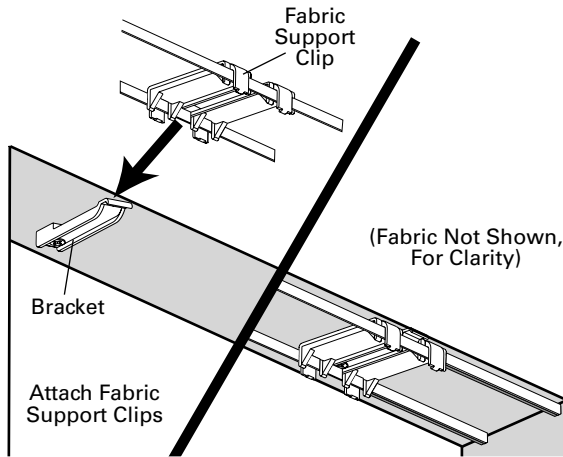

Adjust The Shading

Install The Opposite End Stop Strips (Optional)

After the shading is in place, you may want to install a stop strip to the other end to tension the shading.

1. Gently pull on the end of the front polystrip to lightly tension the strip and smooth the face fabric.
2. Peel the backing off of the short adhesive-backed plastic stop strips.
3. Adhere the stop strip to the tensioned polystrip at the other end of the bracket edge to maintain tension.
4. Trim the excess stop strip flush with the edge of the shading.

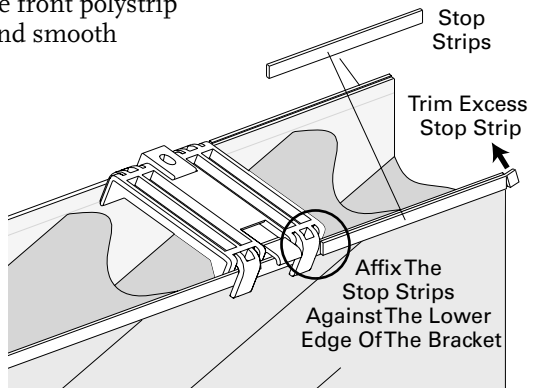

Shim Unlevel Shadings

Some shapes, such as a trapezoid shading that is wider on the bottom than the top, may not hang level.

- To correct, add a spacer between the bottom rail and the window sill to support the bottom rail. If there is no window sill, add the spacer to the straight side.



Trapezoid

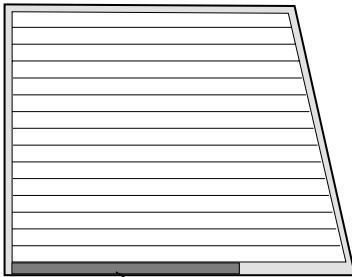

Add Spacer To Sill

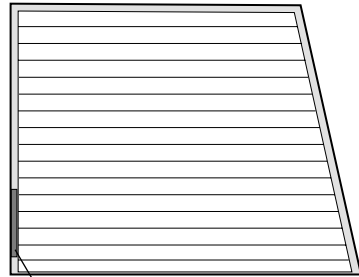

Add Spacer To Side (If No Sill)

Remove The Shading

1. Push down on the installation bracket tabs.
2. Slide the fabric support clips forward to remove the shading.

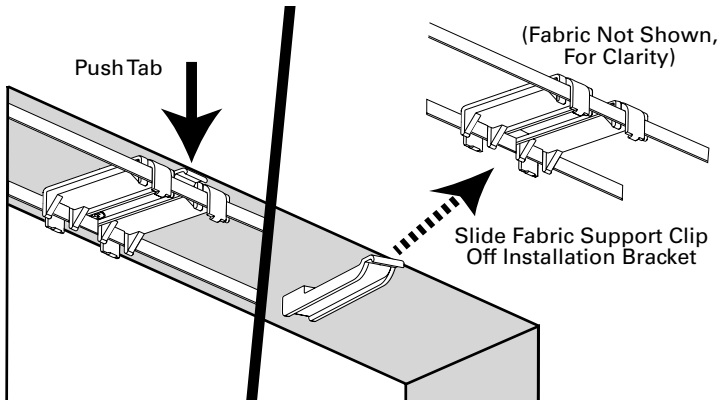

TROUBLESHOOTING

Problem	Solution
<p>The shading does not appear to hang straight.</p>	<ul style="list-style-type: none"> ■ There is lack of tension between the clips, resulting in puckering or sagging. Retension the shading by removing and reattaching the polystrip stops. See <i>Mount The Shading</i>, page 20. ■ The window casement may be uneven. Shim the brackets using the supplied plastic washers, as necessary. See <i>Install The Brackets</i>, page 18.
<p>The shading is not centered in the window.</p>	<ul style="list-style-type: none"> ■ Add clearance on one side. ■ Trim the polystrip stops: <ul style="list-style-type: none"> - Remove the polystrip stops on the side to add clearance. - Trim the stops slightly and reaffix. See <i>Mount The Shading</i>, page 20. - Slide the end fabric support clip until it rests against the stop. ■ Adjust the fabric support clips by sliding them slightly away from the adjusted side. ■ On the opposite side: <ul style="list-style-type: none"> - Remove the polystrip stops. - Tension the fabric. - Reaffix the stops. See <i>Mount The Shading</i>, page 20. - Slide the end fabric support clip until it rests against the stop.
<p>There are twists in the shading fabric.</p>	<ul style="list-style-type: none"> ■ Remove tension on the fabric: <ul style="list-style-type: none"> - Shim the installation brackets, or - Place a shim on the window sill, allowing the bottom rail to rest on the sill. See <i>Shim Unlevel Shadings</i>, page 21.

CARE AND CLEANING

Silhouette® window shadings are made of 100% polyester, which means they are inherently durable and resilient. However, care must be taken to avoid wrinkling the fabric, particularly where the vanes meet the facings.

Dusting

Regular light dusting with a feather duster is all the cleaning that is needed in most circumstances.

Vacuuuming

Use a low suction, hand-held vacuum for more thorough dust removal.

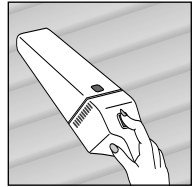

Forced Air

Blow away dirt and debris between the vanes using clean compressed air or a hair dryer set on a “cool” setting.

Spot-Cleaning

Do not spot-clean Silhouette window shadings.

Ultrasonic Cleaning

Silhouette shadings can be ultrasonically cleaned by a professional, **with the exception of Bon Soir™ light-dimming fabric.**

- Specify that a mild detergent solution be used.
- Dry the shading completely in the lowered position.

Electrostatic Cleaning

Do not use electrostatic cleaning devices such as Swiffer™ or Pledge Grab-it™ on any Silhouette window shadings.

For more comprehensive cleaning instructions, call the Hunter Douglas Customer Information Center toll free at:

1-888-501-8364

A Note About Silhouette Fabric

As with all textiles, Silhouette fabric is subject to some variations. Slight wrinkling, puckering, or bowing is inherent to this textile product and should be considered normal, acceptable quality. These characteristics are not usually visible from the front or rear but may be visible from a side angle.

Precautions should be taken to reduce exposure to harsh environmental elements, such as salt air. Continuous exposure through open windows and doors will accelerate the fabric deterioration.

**Questions? Call the Hunter Douglas
Customer Information Center at**

1-888-501-8364

Visit our Web site at hunterdouglas.com



HunterDouglas

LIGHT CAN CHANGE EVERYTHING™

hunterdouglas.com

© 2005 Hunter Douglas Inc. ® Registered trademark of Hunter Douglas Inc.
™ Trademark of Hunter Douglas Inc. Patented in the U.S. and foreign countries.

Other U.S. and foreign patents pending.
Swiffer™ is a trademark of Procter & Gamble.
Pledge Grab-It™ is a trademark of SC Johnson.



PCN5107230000

8/05